

Lube Level Maintainer LM500/LM500-TF

The LM500 maintains oil level on any size engine. It also supports installations that require a three-wire, snap-action switch. The form C (three-wire) contact allows a controller/annunciator to be wired as a closed-loop system, resulting in a reliable fault-sensitive circuit. Refer to LM500 Series Flow Rate Chart for application data.

The Murphy LM500-TF Oil Level Maintainer includes a test feature that confirms both the float and switch are operating correctly with a single press of the test button. The LM500 series maintains the crankcase oil level of an engine, pump or compressor. Adjusted to the correct running oil level, it will replenish oil as it is used. The low-level switch will alarm and/or shut-down the equipment, if supply oil is lost and the equipment continues to use oil.

As crankcase oil level drops, the LM500 float also drops and opens the Thumb-Valve™. This allows oil to flow from the supply tank through the LM500 and into the crankcase. When proper level is achieved in the crankcase, the LM500 float rises causing the Thumb-Valve to close off further oil flow.

The simple and unique Thumb-Valve is non-clogging and provides a positive, leak-free seal.

If the clean oil supply is depleted and oil level continues to fall, the low-level switch will operate an alarm or equipment shutdown.



Thumb-Valve Operation

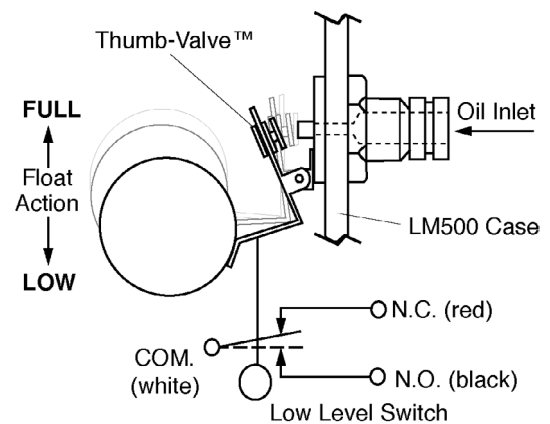

LM500 Series Flow Rates

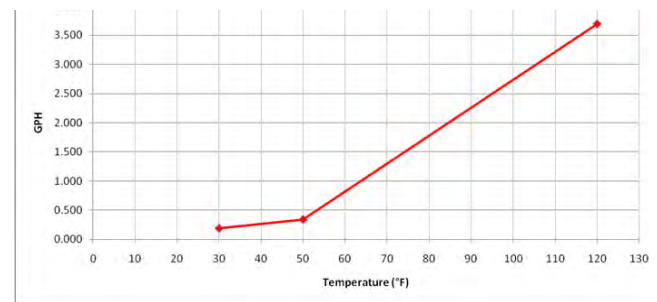

Specifications

- Crankcase Balance Vent Connection:** 1/2 NPTF (top)
- Inlet Connection:** 1/2 NPTF removable screen (side)
- Outlet Connection:**
 - 2 x 3/4 NPTF (side)
 - 1 x 3/4 NPTF (bottom)
- Thumb-Valve™ Material:** Viton
- Snap-switch:** SPDT rating 10 A, 125 VAC; 0.5 A, 125 VDC; 10 A, 30 VDC
- Wire leads:** 18 AWG x 14 in. ± 2 in. (355 mm) length
- Conduit Connection:** 1/2 inch conduit (female, top)
- Case:** Die cast aluminum
- Lens:** Clear Frog Eye non-staining, high-impact, high temperature polycarbonate; UV and heat stabilized
- Dial:** High visibility white background with solid green band for normal level indication
- Maximum Inlet Pressure:** 9.50 psi/25 ft. oil (head pressure)
- Maximum Case Pressure:** 15 psi (103 kPa)
- Maximum Differential:** 2 in. (51 mm) between running and stopped
- Maximum Ambient Temperature:** 250°F (121°C)
- Float:** 304 Stainless Steel
- Flow Rates:** Refer to LM500 Series Flow Rates chart for application data
- Dimensions:** Overall 6-9/16 in. (H) x 6-3/16 in. (W) x 3-1/2 in. (D)
- LM500/LM500-TF Shipping Dimensions:** 9.5 (W) x 7.5 (D) x 11 in. (H) (241.3 (W) x 190 (D) x 279.4 mm (H))
- LM500/LM500-TF Shipping Weight:** 3 lbs. 13.44 oz (1.74 kg)

Mounting Brackets with Hardware

In addition to the direct mounting option, Enovation Controls offers two mounting brackets for the LM500. The pipe bracket fits a 7/8 in. (22 mm) diameter pipe (see typical installation). The Universal Flange Kit allows various mounting methods. For exact dimensions, visit <http://www.fwmurphy.com>.

Typical Installations

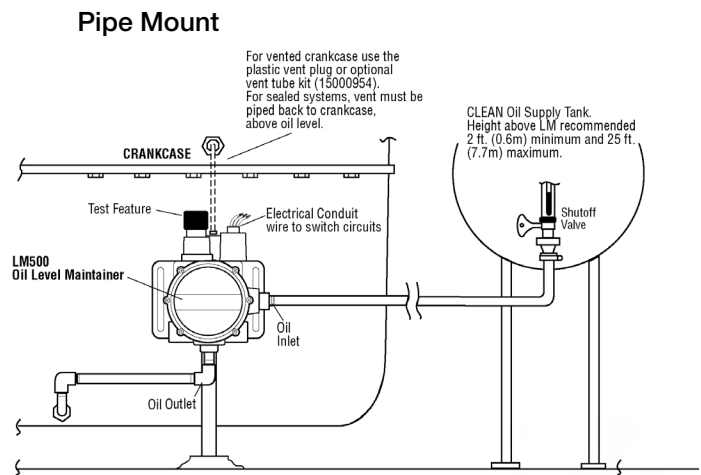
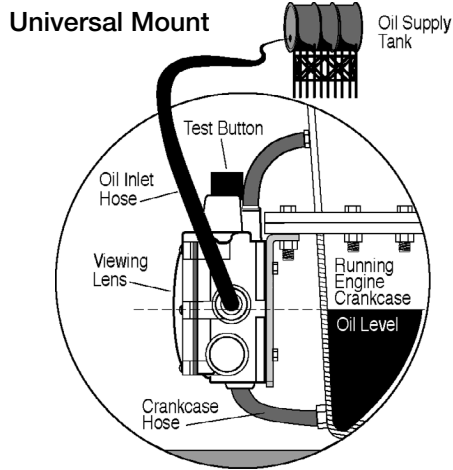

How to Order

Options listed at right. All configurations may not be available. Call your sales representative or Enovation Controls for more information.

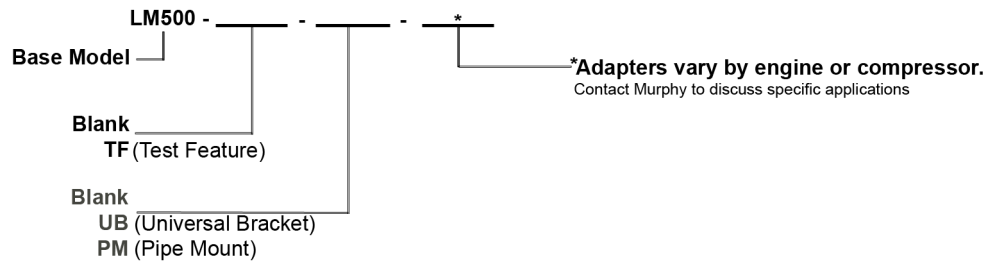

Part Number	Description	Notes
15000954	Vent Fittings Kit	one tubing vent, one 1/4 x 1/2 NPT connector
15000355	Hose Kit	one - 1/2 in. (13 mm) I.D. x 3 ft. (914 mm) hose one - 1 in. (25 mm) I.D. x 3 ft. (914 mm) hose two - 1/2 in. (13 mm) worm gear clamp two - 1 in. (25 mm) worm gear clamp two - 1/2 NPT x 1/2 in. (13 mm) barbed fitting two - 3/4 NPT x 1 in. (25 mm) barbed fitting
89080801	1/2 NPT x 1/2 in. Hose Barbed Fitting	
89081001	3/4 NPT x 1 in. Hose Barbed Fitting	
15000518	Pipe Bracket Kit	
15000519	Universal Flange Kit	
15000532	Bubble Lens Kit	
15000943	Fittings Kit	one tubing vent; one hose barb, 1/2 NPT to 1/2 Hose; one hose barb, 1" ID hose x 3/4 NPT; one connector, 1/4 x 1/2 NPT